

PLAN

IF PATCH MATCHES EXISTING FINISHED GRADE,  
THEN ALL SAWCUTS TO BE SEALED WITH  
APPROVED JOINT SEALANT COMPOUND.

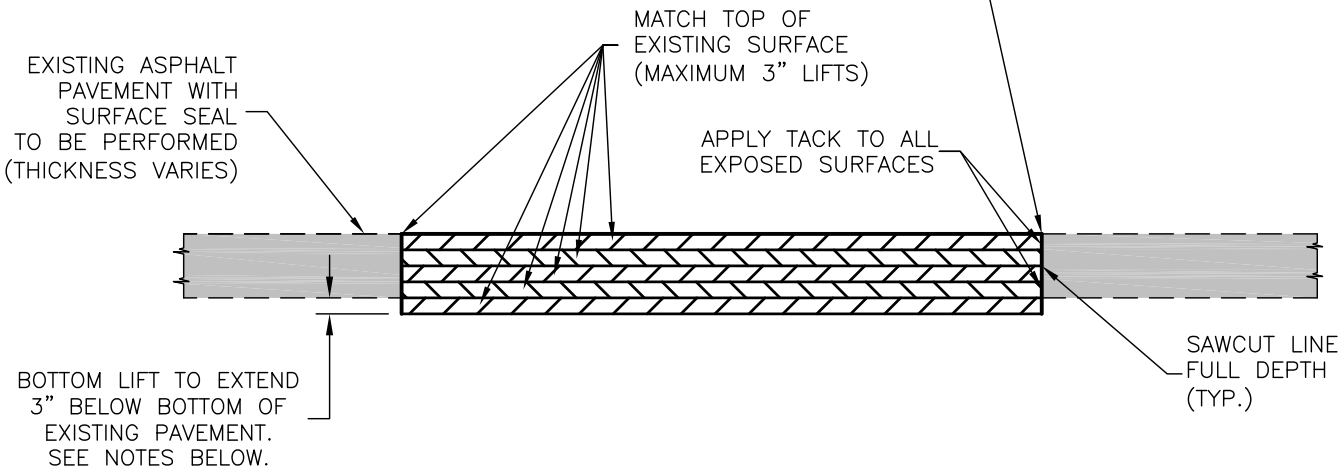

SECTION A-A

NOTES:

- ALL ITEMS SHOWN ABOVE ARE SUBSIDIARY TO THE BID ITEM "ASPHALT PAVEMENT PATCH (FULL DEPTH)"
- THE THICKNESS OF THE ASPHALT PATCH SHALL BE 3" GREATER THAN THE EXISTING PAVEMENT THICKNESS.

CITY OF LAWRENCE, KANSAS  
 ASPHALTIC CONCRETE PATCHING DETAILS  
 (SURFACE SEAL PREP)

04/19/2007